

How to Keep Your Cool While Working With Power Electronics: Static Thermal Design Issues

Robert Balog
April 7, 2003

Purpose:

To present a introductory level tutorial on static thermal issues in power electronics.

Importance of thermal management:

The maximum power dissipation rating listed on most part spec-sheets is overly optimistic and valid for only highly ideal situations. It is important to understand how these ratings are obtained.

Example 1: MTP50N06 [1]

$$42\text{A}, 60\text{V}, 0.028\ \Omega, P_D(\text{max})=125\text{W}, T_j(\text{max})=175^\circ\text{C}, \theta_{j-c} = 1.2 \frac{^\circ\text{C}}{\text{W}}$$

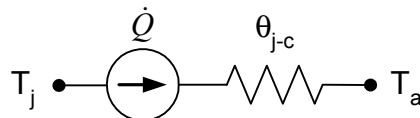

Figure 1: Thermal circuit

$$T_j = T_a + R_\theta \cdot P_D \quad (1.)$$

$$\begin{aligned} T_j &= 25^\circ\text{C} + 1.2 \frac{^\circ\text{C}}{\text{W}} \cdot 125\text{W} \\ &= 175^\circ\text{C} \end{aligned} \quad \leftarrow \text{Max junction temp.}$$

This quick calculation implies that the only way to achieve the rated *maximum power dissipation* is to have a “perfect heatsink” or an “infinite heatsink.” The thermal impedance used in the calculation is from the *junction* to *case* only and assumes zero impedance into the ambient. This is practically impossible to achieve. Further, the ambient was assumed to be 25°C (room temperature) which may not be the situation if the circuit is inside an enclosure where the ambient is, say, 40°C or higher.

About the closest thing on *earth* to a ideal heatsink is the side of a submarine at the bottom of the ocean. The water has essentially infinite heat capacity compared to the total heat generated by our transistor. However, the designer would still need to account for the thermal impedance of the walls of the submarine.

We might be tempted to think that space is the perfect heatsink with a temperature usually assumed to be 0K. However, the lack of a participating fluid precludes convection – the mechanism eventually responsible for convective dissipation of heat into the ambient. Thermal radiation become the sole heat-loss mechanism in space, but can also be a non-zero factor in “room temperature” terrestrial designs.

Manufacturer's data sheets:

Most beginning engineers are probably overwhelmed with all the information presented in the manufacturer's datasheets for a part. For something as “trivial” as a FET, these datasheets can contain eight (8) or more pages. However, to get a prototype running on the bench, most designers only read the first few sheets containing the specs, operational description, and ratings. The last few pages are often ignored or not even printed.

In general, these last pages contain the information that separates a “bench-top prototype” from a “ready to ship” commercial product. Included in this information is MTBF and other reliability data, pulsed power thermal response (thermal time constant), and usually a collection of curves plotting temperature dependency of various parameters. All silicon processes have temperature dependent drift associated with them. Take as an example a UC3526 PWM IC, a common part in our lab. Figure 2 illustrates the temperature dependency: as the device undergoes a thermal cycle, the frequency of oscillation can change by ± 1500 ppm ($\pm 0.15\%$). Instead of the learning this the “hard way” on the bench, this phenomenon can be predicted by carefully reading the datasheets. However, in the interest of time, often the designer will race to prototype and have to worry about these “details” later.

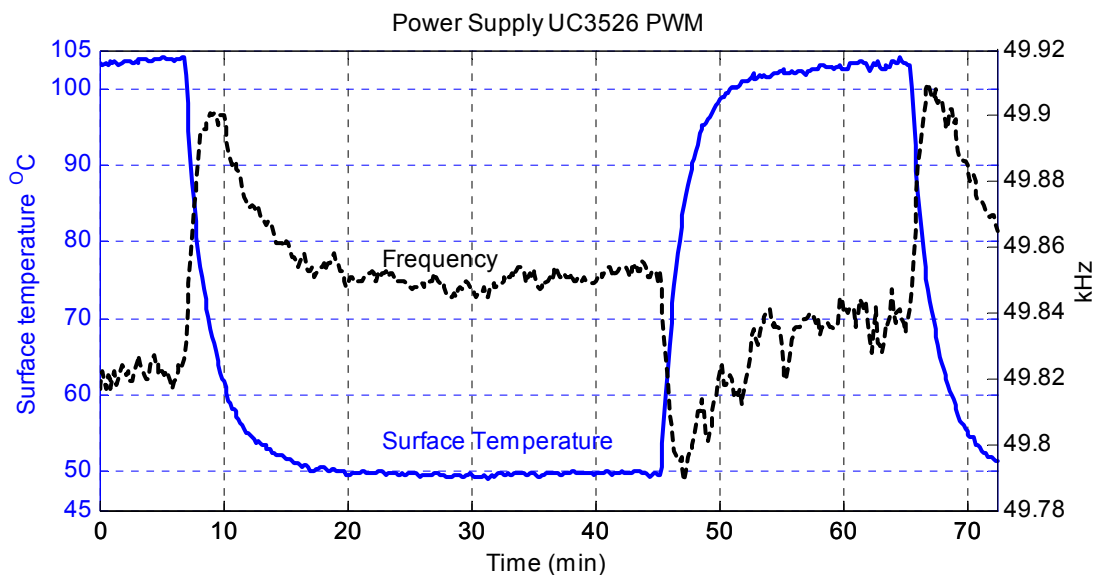

Figure 2: Oscillator frequency as a function of temperature

The lesson to take home is that even for the PWM IC, thermal management is important to ensure stable (or at least predictable) circuit operation. Placing this component close to a thermal generator would be a poor design. Perhaps adding a heatsink to the UC3526 IC would mitigate a significant portion of the oscillating frequency drift.

Sources of heat in a power device:

From a first level course in power electronics[2], we know that power loss in a semiconductor “switch” occurs for two reasons: static dissipation due to the on-state resistance $R_{ds(on)}$ and dynamic losses due to commutation. Calculating the static loss is often straightforward and is typically done by using the average value of the drain (or

collector) current. This is often acceptable except for cases when the drain current is high but has a small duty ratio (high crest factor). For these cases, the designer might consider *peak pulse power* instead of *average power*. Calculating commutation losses is more difficult and requires knowledge of the commutation process. A phase portrait of the commutation interval can assist in experimentally computing these losses. The commutation losses can easily be 25% to 100% of the static losses.

Example 1 illustrated that 125W of power dissipation in a power FET is unrealistic. The practical question becomes how much power can safely be dissipated in a device? In the sense of power processing, the FET in the example can handle $60V \cdot 42A = 2,520W$. Static and switching losses are on the order of 2% are clearly too high (50W), even if an aggressive heatsink is used.

From the datasheet for the FET[1] in example 1, the total thermal impedance of the FET without a heatsink, from the junction to the ambient, is $\theta_{j-c} = 62.5 \text{ }^\circ\text{C}/\text{W}$. A rule of thumb for TO-220 packages is about $60 \text{ }^\circ\text{C}/\text{W}$. From equation (1), the maximum power that can be dissipated in a TO-220 device without a heatsink at room temperature is:

$$P_d = \frac{T_{j(\max)} - T_a}{\theta_{total}} = \frac{175^\circ\text{C} - 25^\circ\text{C}}{62.5 \text{ }^\circ\text{C}/\text{W}}$$

$$= 2.4\text{W} @ 25^\circ\text{C}$$

The conclusion should be obvious: the issue of thermal management quickly becomes critical.

Sources of thermal resistance:

While modern power semiconductors are pushing the boundary of reduced losses, an inevitable fact of power electronics is power loss in the solid-state switching devices. Power loss translates into heat generated. Ultimately this heat must be dissipated to the environment. However, the thermal circuit from heat source to heat sink is not perfect and can be categorized by the thermal resistance. A typical thermal circuit is a series path of multiple thermal resistances as shown in Figure 3. It is important for the designer to understand which of these thermal resistances is fixed and which ones can be changed by design.

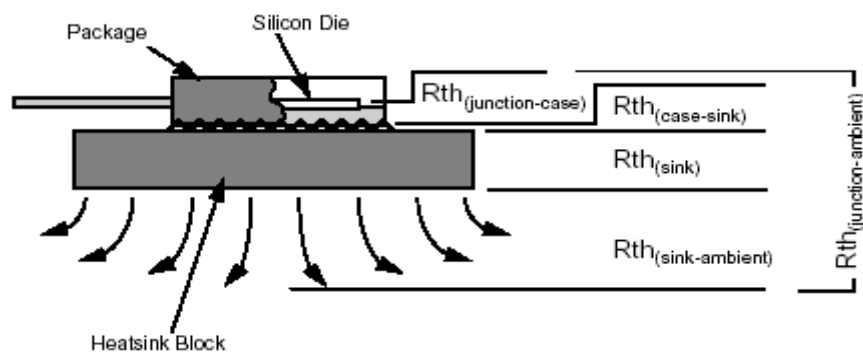

Figure 3: Thermal resistances in a system [3]

The thermal resistance from the junction, the source of the heat, to the case θ_{j-c} of the device (the tab) is fixed by the manufacturing process of the device as well as a function of the geometry of the packaging. Newer packaging solutions such as the SUPER-220 and SUPER-247 offer improvements over the older TO-220 and TO-247 packages. The only choice the designer has is the best packaging.

The thermal resistance from the case to the sink, θ_{c-s} is often called “contact thermal resistance” as is largely a function of contact area (the size of the power device), intermediate material such as thermal grease or electrical isolation pads, and contact pressure. This is perhaps the biggest source of variability in the entire stack-up and the biggest challenge to manufacturing engineers. Assembly line variability such as too much or too little thermal grease or an un-calibrated torque drive can significantly change the thermal circuit.

The thermal resistance of the heatsink and the heatsink to ambient are usually characterized by one value, θ_{s-a} . The designer has numerous options.

Thermal “solutions”:

There are numerous solutions available for the thermal management problem. Figure 4 illustrates broad categories of thermal management technology, achievable thermal resistances, and system cost.

Perhaps the most well known are the stamped and extruded aluminum heatsink. Other solutions are more exotic and can involve fan-forced air, heat spreaders, heat pipes, Peltier junctions, refrigeration cycle cooling, or exotic metals such as phase changing wax-based thermal compounds and sophisticated 2-D geometric fin configurations. Some of these techniques rely on the latent heat associated with the passive phase change from liquid to gas or the use of a mechanical pump to compress a liquid and then control the rate of expansion. The more exotic the solutions generally add significant cost to the system. A good, manufacturable, design has the lowest cost and simplest scheme. Perhaps the electrical design can be improved to reduce the losses in the first place.

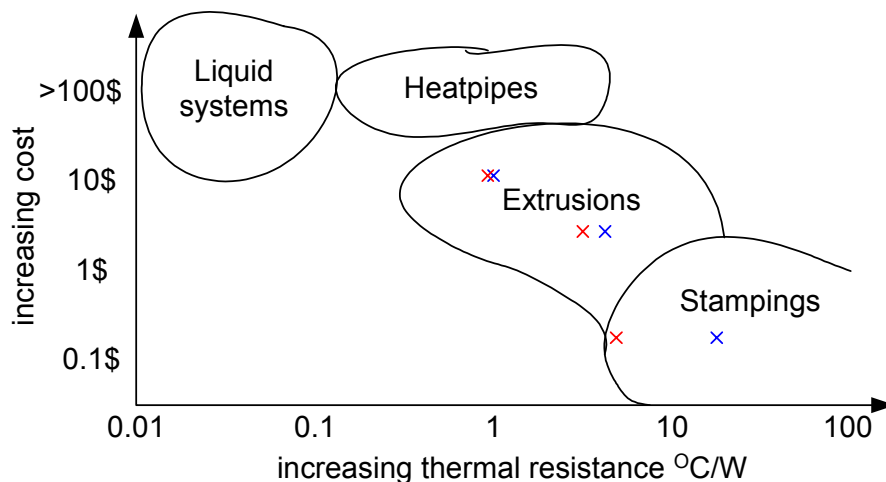

Figure 4: Cost vs. thermal resistance map

Heatsinks:

Most common heatsinks are made from aluminum and are typically black in color. The black color is to assist in radiative cooling while the aluminum is lightweight, cheap and an excellent conductor of heat. Smaller parts are usually stamped and then formed such as the 290 and 237 series parts in Figure 5 while larger heatsinks such as 657 and 403 series are usually aluminum extrusions.

Heat is transferred from the heatsink to the environment by convection and radiation. At room temperature, conduction dominates the total transfer at about 60% with radiation at about 40%. Orientation of the heatsink is critical for maximum performance, especially under natural convection cooling. Natural convection (not fan cooled) takes advantage of the buoyancy of air – hot air rises – to circulate air past the heatsink. Forced convection (fan cooled) relies on a mechanical fan to blow air over the heatsink. Table 1 contains the thermal impedance values for the heatsinks in Figure 5.

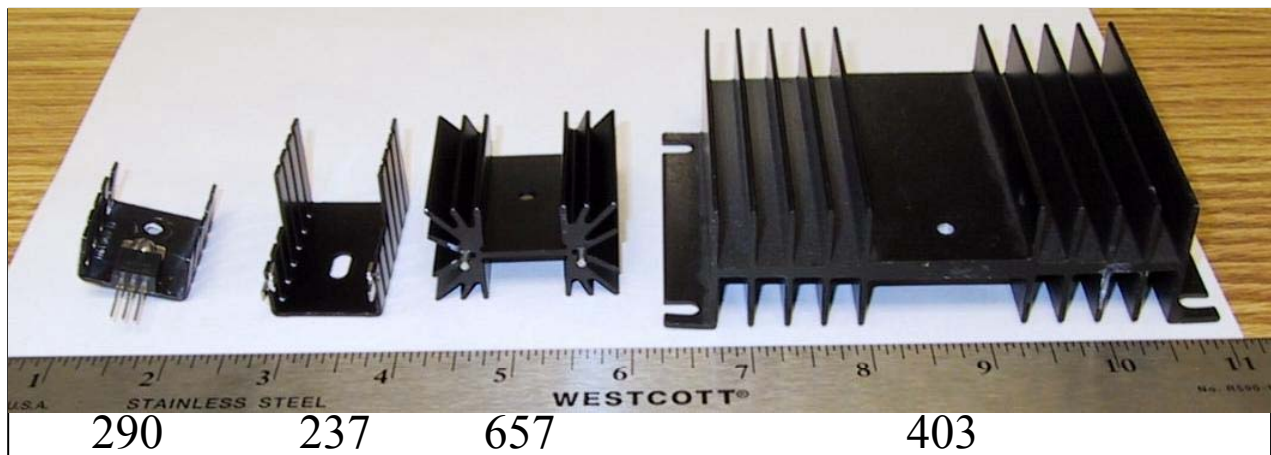

Figure 5: Common heatsinks found in the lab

Table 1: Examples of heatsinks found in the lab

Series	Wakefield PN	Natural Convection		Forced Convection	Dimensions (in)	Weight (lbs)	Cost
273	273-AB	49 °C @ 2W	24.5 °C /W	7.2 °C /W @ 400 LFM	0.750x0.750x0.375		\$0.38
290	290-2AB	44 °C @ 2W	22.0 °C /W	7.0 °C /W @ 400 LFM	1.000x0.710x0.500	0.0055	
237	237-167AB2-24	46 °C @ 4W	11.5 °C /W	4.5 °C /W @ 200 LFM	1.000x1.000x1.675		
657	657-15ABP	38 °C @ 6W	6.33 °C /W	3.3 °C /W @ 200 LFM	1.650x1.000x1.500	0.0760	\$4.37
403	403K	55 °C @ 30W	1.83 °C /W	0.9 °C /W @ 250 LFM	4.000x3.000x1.250	0.3500	\$12.28

In almost all heatsinks, the thermal impedance is a function of power dissipated. Fluid flow mechanics tells us that as the heatsink gets hotter, the surface boundary layer of the air (fluid) and heatsink (solid) changes. At cooler operation, the airflow over the fins can be assumed to be laminar. As the air heats up, the flow becomes turbulent. Because of the vigorous agitation of the turbulent flow, the heat transfer rates are usually much higher[4]. Under forced convection, the flow rates are usually high enough to preclude laminar flow and the forced motion of the fluid results in an overall higher heat transfer coefficient than with natural convection. The designer must weight

the advantages of using forced convection cooling and a smaller (cheaper) heatsink with the disadvantages of the dependence on a fan and the increased opportunity for failure.

Most fans are rated in terms of volume of air, CFM (cubic feet per minute.) To convert to velocity, divide by the cross-sectional area of the fan. The volumetric flow rate of the fan is usually given with no backpressure. A derating of 60% to 80% provides a more realistic rate[5].

Thermal insulation vs. Electrical insulation:

A problem encountered in power electronics is that FET and BJT based devices often have their metal tabs connected to the worst possible electrical node. For example, in most of the common topologies, the drain of a N-type FET is connected to the highest circuit voltage and very rarely chassis or *earth* ground. From a thermal perspective, there is good reason. The drain or collector wells are usually the largest in size and represent the lowest thermal impedance connection between the junction and the tab.

The result is that the tab is almost always electrically *live* with respect to the chassis. This prevents directly mounting the devices to the enclosure. Further, it is poor practice to have an electrically live heatsink inside an enclosure, even if the system voltage is low. The only way to address both the thermal and electrical requirements is to insert a spacer that has high thermal conductivity and low electrical conductivity.

Thermal Grease:

Most thermal greases are silicone based with metal oxide fillers to improve thermal conductivity. The color is typically white to off-white, the consistency like thick extremely greasy. Since grease is highly non-polar, typical solvents like water don't do a great job of cleaning up mistakes or hands. Typically alcohol with dangling –OH groups or non-polar solvents work much better. Surprisingly, regular soap, with a polar head and non-polar tail does only a fair job of removing it from your hands.

Contrary to popular belief, “If some is good, more is *not* better” when it comes to thermal grease. In fact, from Table 3, the thermal conductivity of thermal grease is relatively low, especially compared to the aluminum in the heatsink. In most cases, adding a glob of thermal grease and then squeezing the heatsink onto the transistor may actually hurt your thermal performance.

Example 2: A TO-220 power FET is to be mounted to a heatsink. Assuming that an improper application of thermal grease results in a layer of grease that is $t=0.003''$ thick (about the thickness of one sheet of paper). Proper application would result in no surface buildup, $t=0.000''$. Neglecting any surface oxide, anodization, or paint.

$P_D=6W$ total losses in the device

$A_c=(0.4'' \times 0.6'')=0.24$ sq-in (typ. TO-220)

$$\theta_{j-c} = 1.2 \frac{^{\circ}C}{W}, \quad \text{MTP50N06 transistor (typ. for TO-220)}$$

$$\theta_{s-a} = 6.3 \frac{^{\circ}C}{W}, \quad \text{657 series heatsink}$$

The thermal conductivity of a parallel plane slab (a layer of thermal grease) is calculated:

$$\theta = \frac{t}{k \cdot A_{contact}} = \frac{\rho \cdot t}{A_{contact}}, \quad t = \text{thickness} \quad (2.)$$

$$\begin{aligned} \theta_{grease} &= \frac{t}{\frac{k[W/m \cdot K]}{39.37} \cdot A_c} = \frac{0.003''}{\frac{0.735[W/m \cdot K]}{39.37 m''} \cdot 0.24 sqin} \\ &= 0.670 \frac{^{\circ}C}{W} \end{aligned}$$

First, assume no layer of thermal grease. The thermal circuit is shown in Figure 6. For the moment, we neglect the contact thermal impedance between the case and sink and compute the temperature rise from junction to ambient:

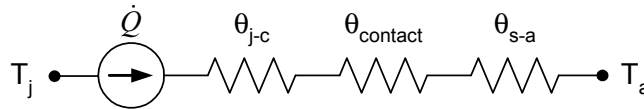

Figure 6: Thermal circuit

$$\begin{aligned} T_j - T_a &= P_d \cdot (\theta_{j-c} + \theta_{contact} + \theta_{s-a}) \\ &= 6 W \cdot \left(1.2 \frac{^{\circ}C}{W} + \cong 0 \frac{^{\circ}C}{W} + 6.3 \frac{^{\circ}C}{W} \right) \\ &= 45 \text{ } ^{\circ}C \end{aligned}$$

Now, rework the problem with the 0.003'' layer of thermal grease:

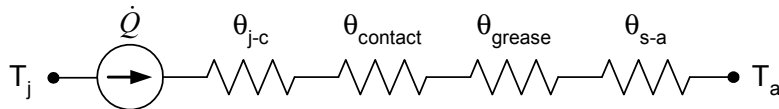

Figure 7: Thermal circuit with thermal grease

$$\begin{aligned} T_j - T_a &= P_d \cdot (\theta_{j-c} + \theta_{contact} + \theta_{grease} + \theta_{s-a}) \\ &= 6 W \cdot \left(1.2 \frac{^{\circ}C}{W} + \cong 0 \frac{^{\circ}C}{W} + 0.67 \frac{^{\circ}C}{W} + 6.3 \frac{^{\circ}C}{W} \right) \\ &= 49 \text{ } ^{\circ}C \end{aligned}$$

The insulating effect of the thermal grease results in an additional 4°C temperature rise with only 6W dissipated! At 30W dissipated, the result is 20°C rise.

The real benefit of thermal grease is at the microscopic level where imperfections on each of the mating surfaces reduce the contact area as in Figure 8. At a microscopic level, the surfaces are far from smooth. The microscopic gaps create air pockets and prevent good metal to metal contact when mated. From Table 3, the thermal conductivity of thermal grease is approximately 25 times that of stagnant air. Proper use of thermal grease fills these microscopic gaps, providing a much lower impedance thermal path than the air, thus augmenting the metal to metal conduction with conduction through the grease.

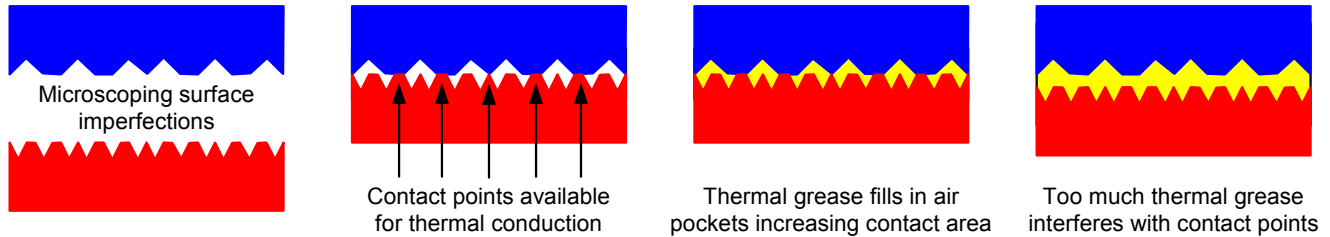

Figure 8: Micro-scoping surface interface

The proper technique when applying thermal grease is to apply as thin a film as possible. Industry often uses a squeegee process with high contact pressure to force the thermal grease into the microscopic voids then wipes the surface clean. In the lab, a foam swab can be used to “rub in” the grease and remove excess from the surface. If grease squeezes out when the heatsink is mated there was too much applied. Worst, there is still probably too much trapped between the interface deteriorating performance.

Table 2: Typical Contact resistance for SUPER-247 [3]

Contact condition	Thermal Resistance @ 20N
‘Dry’	1.2 °C/W
Thermal compound	0.2 °C/W

On a final word, some thermal greases are electrically conductive! Even if they do not conduct dc, they can significantly reduce the breakdown voltage and facilitate arcing. Also, many of the thermally conductive / electrically insulating materials do not require thermal grease, i.e. “greaseless.”

Thermo-physical properties of materials:

A partial list of thermo-physical properties of metals and non-metals is shown in Table 3. For metals, thermal conductivity, k typically decreases with temperature. For non-metals, k typically increases with temperature.

Table 3: Thermal properties of materials ^{4} except as noted

Material:	Category	Thermal conductivity: W/m-K	Notes:
Diamond	Insulator	550 – 1,000+	Depending on purity, temperature
Copper (pure)	Metal	386	
Aluminum	Metal	160 – 230	
Copper (brass)	Metal	111	
Steel (carbon)	Metal	43-64	
Steel (stainless)	Metal	15-25	
Aluminum oxide (alumina)	Insulator	27-36	
Polyamide (nylon)	Insulator	0.24	typical of plastics
Air	Insulator	0.025 – 0.031	at 1 atm
Wakefield Thermal Compound # 120 [6]	Insulator	0.735	“thermal grease”
Sil-Pad® and other greaseless interface	Insulator	0.25 – 1.0	electrical isolation

Frequently it becomes necessary to convert between the MKS and SAE systems when working with thermal properties. To convert between mks and SAE thermal conductivity:

$$1 \frac{\text{BTU} \cdot \text{Inch}}{\text{ft}^2 \cdot \text{hr} \cdot ^\circ \text{F}} = 6.933 \frac{\text{W}}{\text{m} \cdot \text{K}} = k \quad (3.)$$

$$k = \frac{273.2}{\rho} \text{ mks system} \quad (4.)$$

To convert between mks thermal conductivity and SAE thermal resistivity:

$$k \left[\frac{\text{W}}{\text{m} \cdot \text{K}} \right] = \frac{39.4}{\rho \left[\frac{^\circ \text{C}}{\text{W} \cdot \text{Inch}} \right]} \quad (5.)$$

Temperature measurement techniques:

One obvious and often used technique is to touch the part. The result is a burnt finger and no further insight into the problem. There are two common techniques that can be used to measure temperature in the lab: IR (infra red) temperature probe and a thermocouple. As with any instrument, it is important to understand the operation and limitations of the equipment.

The laboratory has numerous IR temperature probes that can be used to quickly measure the temperature of components in the circuit. The IR temperature probe is convenient to “probe” around in the circuit looking for hot spots. It is important to remember that the IR probe works by measuring the intensity of the radiation emitted from the device. The relative intensity is converted into a voltage usually in the 0 – 300mV range with 1°C=1mV. In general they have a narrow field of view and are calibrated for a specific emissivity, usually black. Trying to read the temperature of the metal tab will result in an error due to the low emissivity. Similarly, an enclosure that is highly reflective can produce multiple reflection of the radiated energy and introduce measurement error. In some instances it is desirable to spray paint the entire circuit, pcb, and enclosure flat black to ensure accurate measurement.

Thermocouples can also be used to take temperature measurements. The thermocouple, a junction of two dissimilar metals, generates a small voltage proportional to temperature. Therefore the measurement is the temperature directly, not a representation of it. Different types of thermocouples exist for different temperature ranges. Type J (iron – constantan) is most suitable for use in a typical power electronics application. Insulation material and wire gauge is also an important factor. Heat is conducted down the length of the wire. Therefore large diameter wires will result in a large discrepancy between measured temperature and actual temperature. The quality of the insulation will determine convective cooling along the length of the wire, also contributing to error.

The thermocouple can be attached to the DUT (device under test) by applying a small dab of quick-setting glue. If the thermocouple is not in good mechanical contact with the surface, then the thermal conductivity of the glue introduces an error between actual and measure temperature. The use of a two part glue and activator system is convenient for making quick but durable bonds that can be removed most surfaces after the test is complete.

At with the IR probe, is it important to understand what is being measured. If the thermocouple is bonded to the body of the FET, then the case temperature is being measure. Knowledge of power dissipated and junction to case thermal resistance is needed to calculate the actual junction temperature.

Mounting techniques:

Mounting the semiconductor to a heatsink is non-trivial. The way in which the device is mounted can influence the effectiveness of the heatsink as demonstrated in example 2 with excess thermal grease. It is good practice to assume that the heatsink is electrically connected to earth. Therefore, an important consideration is electrical isolation of the exposed metal tab (if any) of the power semiconductor.

If electrical isolation is not an issue, thermal grease and a heatsink are a good choice for mounting power devices. However, in most cases electrical isolation will be a requirement. In this case, the tab cannot be directly connected to the heatsink. Figure 9 illustrates one method of mounting using an electrically insulating / thermally conducting pad, labeled (1). The 4-40 1/2" screw (5) is prevented from touching the electrically live tab by a shoulder washer (2).

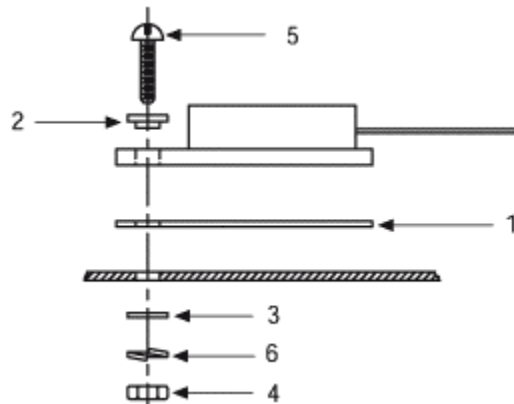

Figure 9: Mounting a device with a tab to a heatsink [5]

The material used for the spacer needs to withstand impressed voltage and minimally impeded heat flow. Examples of materials typically used are mica, polyimide films such as Kapton® by Dupont, impregnated silicone rubber such as Sil-pad® by Bergquest, or phase changing compounds. An example of a electrically isolative thermal interface used in our lab is Sil-Pad® 400 from Bergquist. Available from a number of venders (Digikey: part number: BER109-ND), the pad is large enough to fit either a TO-220 or the larger TO -247 package. The breakdown voltage is 3500 - 4500 V_{ac} [7] and it has a thermal resistance of 0.35 °C -in/W (thermal conductivity of 1.0 W/m-K,) adding between 3.6 °C/W and 8.5 °C/W for a TO-220 package.

An important factor in the effectiveness of the thermal circuit is the contact force between the case and the sink, θ_{cs} . Figure 10 illustrates this relationship for a SUPER-247 in three different mounting configurations. As expected, properly applied thermal grease lowers the thermal contact resistance and the cost of electrical isolation by a insulator pad is higher contact thermal resistance. In general, although a nylon screw provides electrical isolation, it cannot generate the required contact force for larger power semiconductors. The in the past, the preferred mounting method was a steel screw with a shoulder washer and isolation pad to proved the electrical isolation. Now, with the SUPER-220 and SUPER-247 packages devoid of a mounting hole, clip systems are becoming more favorable. Clip systems offer numerous advantages over a system such as in Figure 9. First, manufacturing costs are reduced by eliminating the labor intensive assembly process. Second, clip system tend to distribute the contact force more evenly across the entire device instead of concentrating it at the location of the mounting hole.

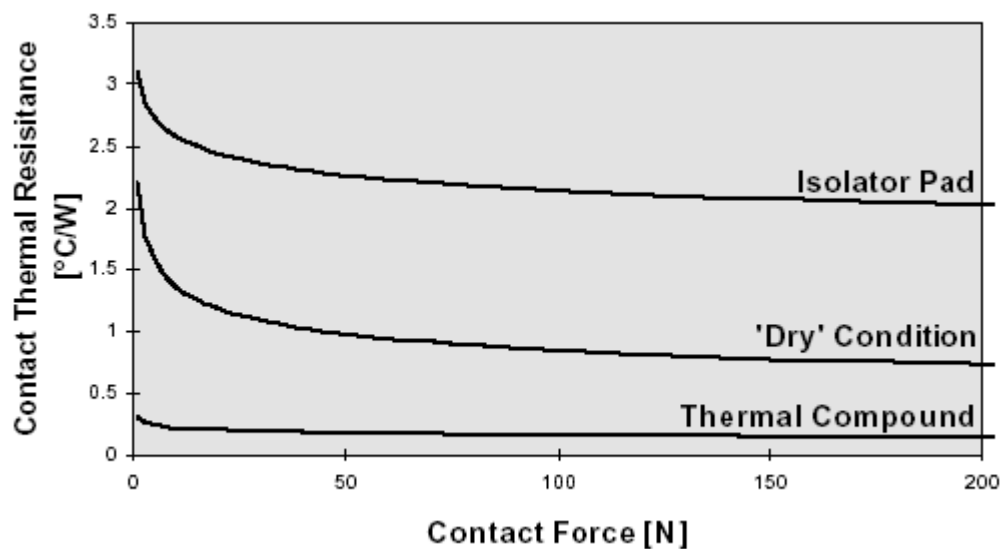

Figure 10: Thermal resistance vs. Contact force SUPER-247 [3]

References:

- [1] "MTP50N06V Designer's Data Sheet," Motorola 1996.
- [2] P. T. Krein, *Elements of Power Electronics*. New York: Oxford University Press, 1998.
- [3] A. Sawle and A. Woodworth, "Mounting Guidelines for the SUPER-247," IRF AN-997, www.irf.com.
- [4] A. F. Mills, *Heat Transfer*, 2nd ed. Upper Saddle River, NJ: Prentice Hall, 1999.
- [5] "Standard Products for Thermal Management," AAvid Thermalloy 2001, www.aavidthermalloy.com.
- [6] "Thermal Management Solutions Catalog," Wakefield Engineering, www.wakefield.com.
- [7] "Sil-Pad® 400 Product Datasheet," Bergquist Company, PDS-0602-001-01 Rev 01, www.bergquistcompany.com.

Appendix: Heat flow basics

Notation:

Thermal Energy: Q , [Joules]

Heat Transfer Rate: $\dot{Q} = qA$, $\left[\frac{\text{Joules}}{\text{s}} \right]$ or [Watts]

Heat flux: q , $\left[\frac{\text{Watts}}{\text{meter}^2} \right]$

Conduction:

Fourier's law: $q = -k \frac{dT}{dx}$

Heat flows in the direction of decreasing temperature. Simply put, heat flows from hot to cold. The implication is that there must exist a temperature gradient to drive the flow of heat – there is no such thing as a perfect heatsink with zero temperature gradient.

Convection:

Newton's law of cooling: $q_s = h_c(T, v) \cdot \Delta T$, $h_c = \text{convective heat transfer} \left[\frac{W}{m^2 K} \right]$
 $\dot{Q} = h_c A \Delta T = h_c A (T_s - T_e)$

Fluid flow can be either forced such as with a fan, or free (natural) driven by buoyancy forces of the density gradient. In either case, the flow can be laminar or turbulent. Turbulent flow is associated with a higher thermal conductivity:

$$\begin{array}{llll} h_c \propto \Delta T^{1/4}, & \text{laminar flow} & h_c = 2 - 25 & \text{free convection} \\ h_c \propto \Delta T^{1/3}, & \text{turbulent flow} & h_c = 25 - 200 & \text{forced convection} \end{array}$$

Radiation:

Radiosity W/m^2 :

$$J = \varepsilon E_b = \varepsilon \sigma T^4, \quad E_b = \text{blackbody emissive power}$$

Stephan-Boltzmann:

$\varepsilon = \text{emittance}$

$$\sigma = \text{Stefan - Boltzmann constant} = 5.67 \cdot 10^{-8} \left[\frac{W}{m^2 K^4} \right]$$